



Desigo™

Current valve

SEA45.5

for AC 24 V pulse/pause control
of electrical loads up to 30 kW

Use

The current valve is used for the control of electric heating elements in heating, ventilation and air conditioning plant, e.g.:

- Electric heating coils
- Fan coil units
- Induction units
- Electric radiators
- Electric underfloor and ceiling heating systems
- Reheaters in fan coil units and supply air ducts
- Convector heaters and panel heating

The current valves are designed to switch the following resistive loads:

Load voltage	Minimum switching capacity ¹⁾	Maximum switching capacity ²⁾
1x AC 230 V	0,092 kW	5.75 kW (= 25A)
1x AC 400 V	0,160 kW	10.0 kW (= 25A)

1) Used for sizing the load; has nothing to do with controllability

2) The maximum switching capacity applies to single-phase applications.

For higher switching capacities, see connection diagrams 1...4.

Type summary

Type	Stock number	Designation
SEA45.5	S55376-C160	Current valve

Compatibility

The current valves can be controlled by any device capable of delivering one of the following control signals:

- AC 24 V pulse/pause control signal
- Proportional DC 0...10 V control signal ¹⁾
- On/off control signal, DC 0 or 10 V¹⁾

1) Requires conversion into an AC 24 V pulse/pause control signal.
The SEM61.4 signal converter is available for this purpose (see data sheet 5102).

Technical design

The current valve is a solid-state power switch (thyristor). It regulates the amount of electrical energy supplied to the connected heating element.

The output power is determined by the AC 24 V pulse/pause control signal. It is switched at the zero-voltage crossing point, in order to avoid the introduction of mains interference.

The control signal and power signal are electrically isolated (by opto-coupler), enabling the controller and the current valve to be powered by different phases.

Mechanical design

The current valve consists of a black aluminum heat sink (with four channels for heat dissipation) suitable for mounting on a DIN rail. A plastic housing accommodating the electronic circuit and connection terminals is snap-mounted onto this base.

The underside of the baseplate has a snap-on facility for fixing the current valve to a DIN rail.

The printed circuit board is not encapsulated. In fact, it is actually ventilated by thermal convection through the unused terminal cavities.

The front plate of the electronics housing accommodates the type label and an electrical diagram to assist with wiring. An operating diagram is printed on the side of the electronics housing, showing the maximum permissible load current as a function of the ambient temperature.

LED display

An LED located on the front lights up when the control signal is "ON".

Engineering

- The equipment must be installed in such a way as to ensure that the permissible ambient conditions are maintained. Ensure adequate ventilation especially when installing current valves in control panels.
- The maximum permissible load current (effective value) is dependent on the ambient temperature. **At temperatures above 60 °C the load current must be reduced (see diagram):**

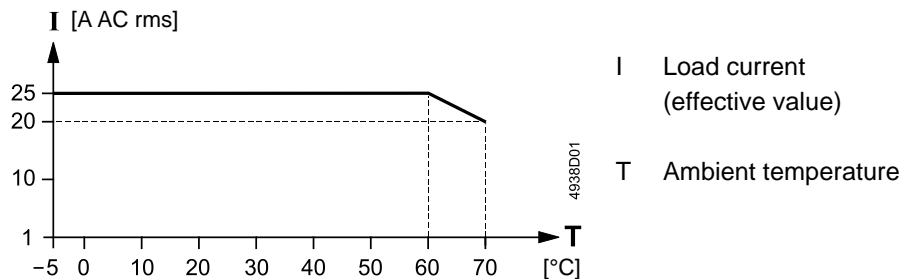

Warning:

- In control panels or fan coil units where the ambient temperature during operation exceeds 40 °C, a fan must be provided for bottom-to-top ventilation.
- **The graph below shows the quantity of heat to be dissipated as a function of the load current. It serves as a basis for calculating the cooling requirements.**

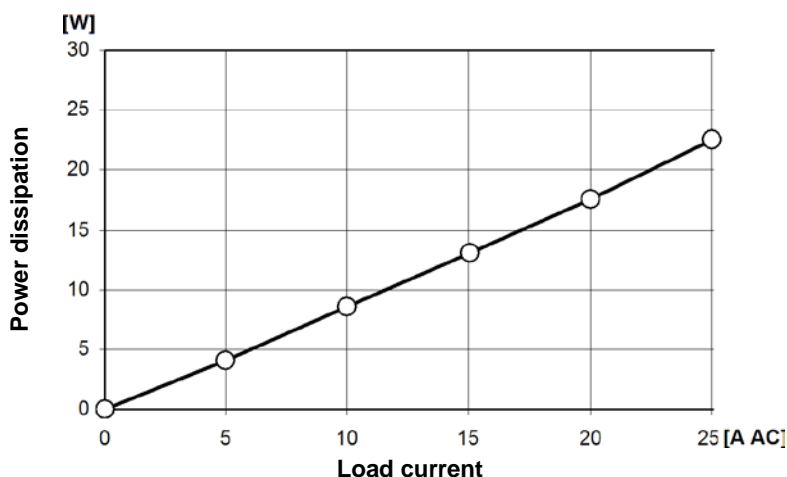

- Mains voltage tolerances must be included in load calculations. The maximum allowable load current of 25 A must not be exceeded.
- The rated current of the connected heating element must not be lower than the minimum load current of the current valve (see "Technical data").
- The load input (terminal L) may only be fused with fast-acting fuses: max. 25 A ($I^2t < 6600 \text{ A}^2\text{s}$).
- The system voltage and load voltage may have different phases.
- At least one thermal cut-out must be provided for protection of a heater battery. This must not be interlocked with the current valve on the control side: instead, it should cut off the power supply to the heating element, either directly or via a switching contactor.
- Heater batteries must not be fitted with short-circuit high-temperature cut-outs.
- The heat sink may be earthed.
- Under normal operation, the heat sink may become very hot (approx. 90°C). Personnel must be warned to avoid touching the heat sink during or directly after operation. Maintained a safe distance from cable ducts.
- The following minimum clearance between the current valve and other devices must be maintained:
 - 10 mm on either side of the current valve
 - 100 mm above the current valve
 - 50 mm below the current valve

Warning:

Mounting and installation

- Mounting location: on wall or in control panel, with forced ventilation precautions where necessary.
- Mounting method: snap-mounting on DIN rail
- Local electrical installation regulations must be observed.
- Mounting instructions are supplied with the current valve.

⚠ Warning:

- **Always install current valves so that the cooling fins are vertical.**
- **Forced ventilation of the control panel must be from bottom to top only, to support natural convection through the heat-sink cooling channels.**
- **Forced ventilation must not be directed horizontally at the devices, as this can impede natural convection through the cooling channels.**
- **Current valves must not be installed one above the other.**

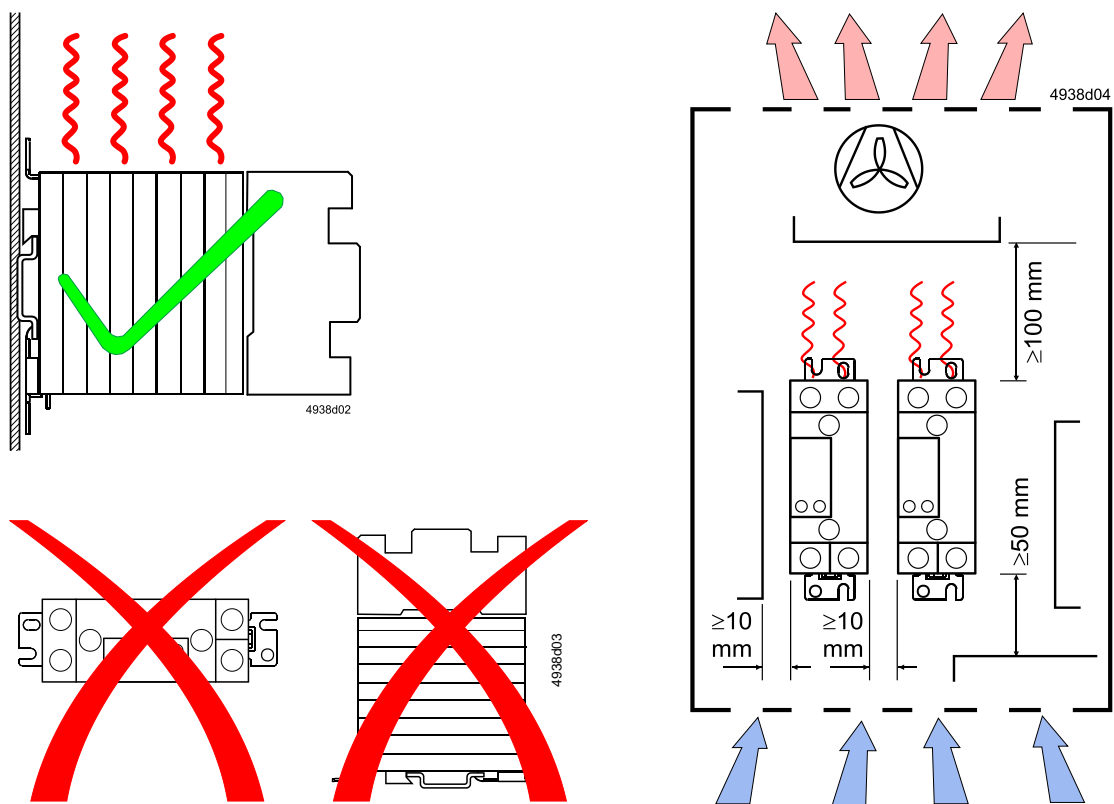

Disposal



The device is considered an electronic device for disposal in accordance with the European Guidelines and may not be disposed of as domestic garbage.

- Dispose of the device through channels provided for this purpose.
- Comply with all local and currently applicable laws and regulations.

Technical data

Control side	Control voltage (Terminal G, Y1)	SELV / PELV AC 24 V \pm 20 %	
	Frequency	50/60 Hz	
	Power consumption (AC 24 V)	0,24 VA	
	External supply line protection	Fuse slow max. 10 A or Circuit breaker max. 13 A Characteristic B, C, D according to EN 60898 or Power source with current limitation of max. 10 A	
	Control signal voltage (pulse/pause) (Terminal Y1)	AC 24 V	
	Switch-on voltage	AC 18.5 V	
	Switch-off voltage	AC 6 V	
Load side	Mains voltage (terminal L, Q)	AC 42...660 V	
	Frequency	50/60 Hz	
	Current, I_{eff} at 40 °C ¹⁾	AC Max. 25 A ¹⁾	Min. 0.40 A
	Power	0,092...5.75 kW (230V)	
	Power	0,16...10 kW (400V)	
	Power loss across thyristor	1...23 W	
	External supply line protection ³⁾	Fast-acting fuse max. 25 A or Fast circuit breaker max. 25 A	
General device data	Switching action	Zero voltage switch	
	Max. cable length (terminals G and Y1) for 0.6 mm diameter Cu cable	300 m	
	Connection terminals on control side	Max 1 x 4 mm ²	
	Connection terminals on load side	Max 1 x 25 mm ²	
	Insulation resistance		
	Control circuit – load circuit	AC 4 kV	
	Load circuit – heat sink	AC 4 kV	
Housing protection standard	IP 20 to EN 60 529		
Protection class	II to EN 60 730		
Ambient conditions		Normal operation	Transport
		IEC 721-3-3	IEC 721-3-2
	Environmental conditions	Class 3K5	Class 2K3
	Temperature ¹⁾	-5...+70 °C ¹⁾	-25...+70 °C
	Humidity (avoid condensation)	5...95 % rh	<95 % rh
Mechanical conditions	Class 3M2	Class 2M2	
Standards, directives and approvals	Product standard	EN 60947-4-3	Low-voltage switchgear and control gear: AC semiconductor controllers and contactors for non-motor loads)
	Electromagnetic compatibility (Applications)	For use in residential, commerce, light-industrial and industrial environments	
	EU conformity (CE)	A5W00056130 ²⁾	
	EAC compliance	Eurasian compliance	
	Environmental compatibility 1)	A6V11679932	
Weight	Weight excluding packaging	0.440 kg	

¹⁾ At temperatures above 60 °C, the load current must be reduced, see page 3.

²⁾ The documents can be downloaded from <http://siemens.com/bt/download>.

³⁾ Note: The value for the load integral of the fuse must be less than the value specified for the current valve (6'600 A²s).

Connection diagrams

Connection diagram

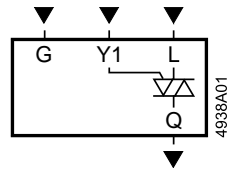

- G System voltage on control side (SELV) AC 24 V
- Y1 AC 24 V pulse/pause control signal
- L Mains potential AC 42...660V
- Q Load (resistive)

Field connection diagrams

The following field-connection diagrams show only the basic connection of the current valves. The diagrams do not show switch-off functions and overrides. These depend on the plant and can vary from system to system.

Connection diagram 1

SEA45.5 with and without signal converter:

1-wire connection plus neutral conductor for AC 42...230 V with 1, 2 and 3 current valves – phases loaded asymmetrically.

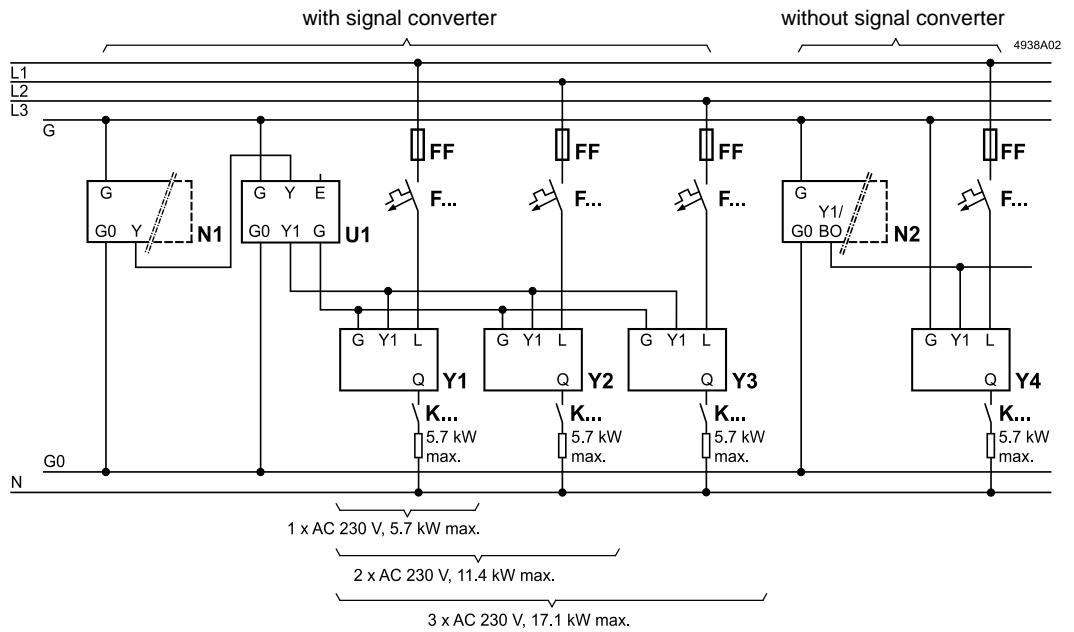

Connection diagram 2

SEA45.5 with and without signal converter:

2-wire connection for AC 42...400 V with 1, 2 and 3 current valves – phases loaded asymmetrically –

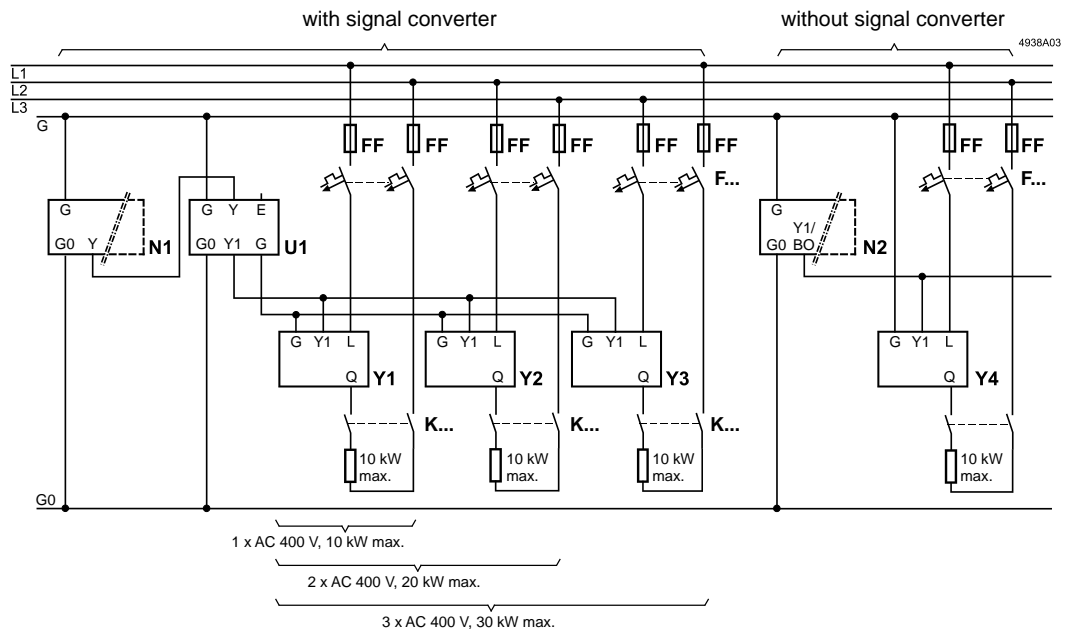

Connection diagram 3
(standard circuit)

SEA45.5 with signal converter:

3-wire connection for AC230 V or AC 400 V – symmetrically loaded phases.

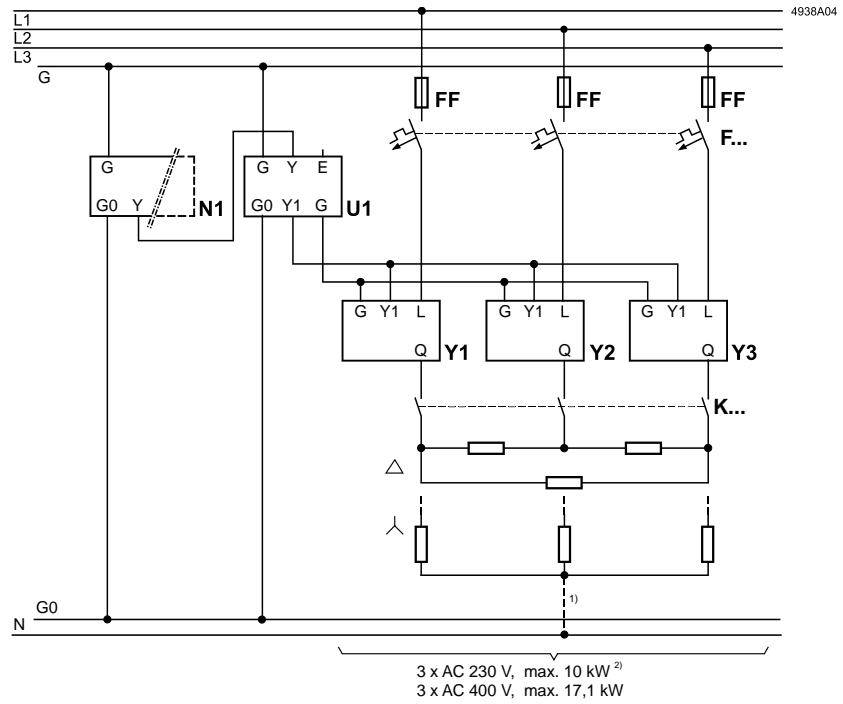

Connection diagram 4
(economy circuit:
CAUTION: Observe all national regulations!)

SEA45.51 with signal converter:

3-wire connection for AC230 V or AC 400 V – symmetrically loaded phases.

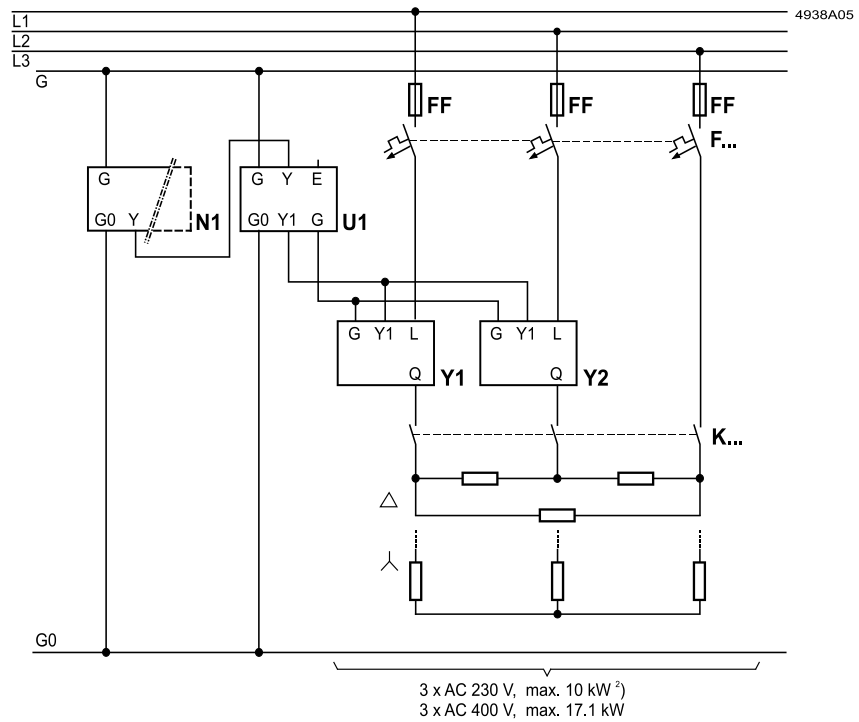

Key to connection diagrams 1 ... 4

- N1 Control unit (e.g. controller) with DC 0...10V or DC 0/10 V output signal
- N2 Control unit (e.g. controller) with AC 24 V pulse/pause output signal
- U1 Signal converter SEM61.4
- Y1...Y4 Current valve SEA45.5
- K... Safety "chain", e.g. safety thermostat and high-temperature cut-out
- FF Fast-acting fuse
- F... Fast overcurrent trip

¹⁾ Star point can be connected to N
²⁾ Valid for a voltage of AC 230 V across the conductors

Dimensions

Dimensions in mm / inch

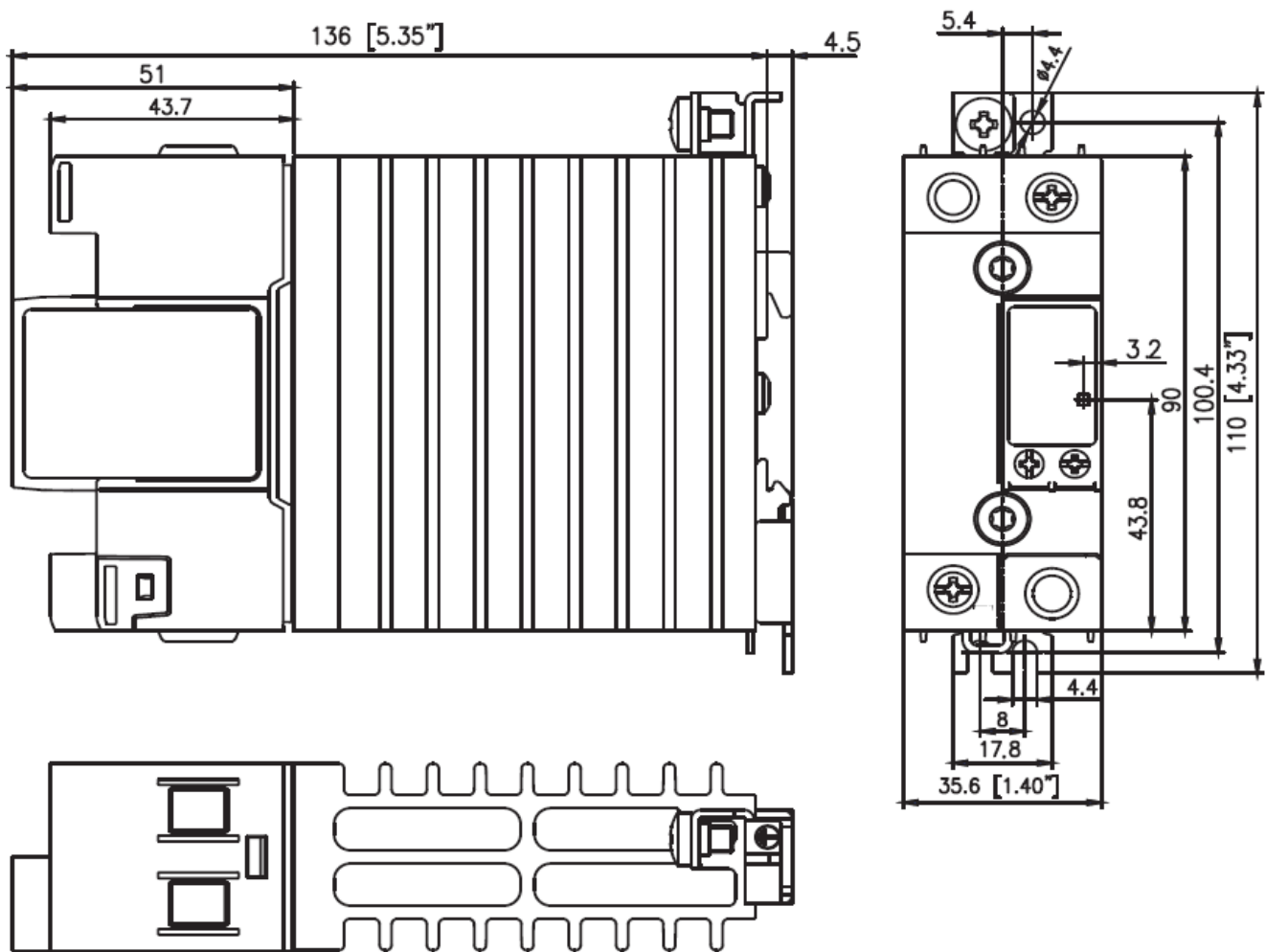

Published by:
Siemens Switzerland Ltd.
Smart Infrastructure
Global Headquarters
Theilerstrasse 1a
CH-6300 Zug
Switzerland
Tel. +41 58-724 24 24
www.siemens.com/buildingtechnologies

© Siemens Switzerland Ltd 2019
Delivery and technical specifications subject to change