

Symaro™

Duct Relative Humidity and Temperature Sensor Modbus RTU

QFM3150/MO



Duct relative humidity (high accuracy) and temperature sensor with Modbus communication

- Modbus RTU (RS-485)
- High measuring accuracy across the entire measuring range
- On-event addressing via push button together with Climatix™ controllers
- DIP switches setting together with other controllers

Use

The duct sensor is used in ventilation and air conditioning plants where high accuracy and short response times for measuring relative humidity are required. The measuring range covers the entire humidity range of 0...100 %.

Examples

- Storage and production facilities in the paper, textile, pharmaceutical, food, chemical and electronics industry, and so on.
- Laboratories
- Hospitals
- Computer and EDP centers
- Indoor swimming pools
- Greenhouses

The sensor is used as a

- control sensor in the supply or exhaust air
- limit sensor for maximum limitation of supply air humidity after a steam humidifier
- limit sensor, for example, for measured value indication or for connection to a building automation and control system

Technical design

Cable entry is made via the screwed cable gland M16 supplied with the sensor, which can be screwed into the housing.

The sensor is fitted with the mounting flange supplied with the sensor. The flange is placed over the immersion rod and then secured to meet the required immersion length.

Service set AQF3153

The service set has three measuring tips without sensor element. Each tip signals a predefined temperature and humidity value to the basic unit:

- 85 % r.h., 40 °C
- 50 % r.h., 23 °C
- 20 % r.h., 5 °C

The fixed values are available at the signal outputs. The values and the test function have the same accuracy. The measuring tips can be exchanged in operation.

Type summary

Product number	SSN NO.	Temperature measuring range	Operating voltage	Output signal
QFM3150/MO	S55720-S468	-40...70 °C	AC 24 V ±20 %/ DC 13.5...35 V	Modbus RTU

Ordering and delivery

When ordering, specify name and product number, for example: Duct sensor QFM3150/MO. Service set AQF3153 (see Accessories) must be ordered separately.

Accessories

Name	Type reference
Filter cap (for replacement)	AQF3101
Measuring tip (exchangeable for replacement)	AQF3150
Service set (for function test)	AQF3153
3 m cable for remote measurement	AQY2010

Engineering

Powering the sensor requires a transformer for safety extra low-voltage (SELV) with separate windings for 100 % duty. When sizing and protecting the transformer, comply with all local safety regulations.

When sizing the transformer, determine the power consumption of the room sensor.

For correct wiring, see the datasheets of the devices with which the sensor is used.

Observe permissible line lengths.

Cable routing and cable selection

Note that when routing cables, the longer the cables run side by side and the smaller the distance between them, the greater the electrical interference. Shielded cables must be used in environments with EMC problems.

Twisted pair cables are required for the secondary supply lines and the signal lines.

Mounting

Location

Mount the sensor in the center of the duct wall. If used together with steam humidifiers, the minimum distance from the humidifier must be 3 m to maximum 10 m.

Mount the sensor in the exhaust air duct if the application involves dew point shifting.

Mount the flange to the duct wall. Then, insert the sensor through the flange and fasten.

- The degree of protection IP65 is not ensured if the seal between the base and cover is removed.
- The sensing elements inside the measuring tip are sensitive to impact. Avoid any impact on mounting.

Mounting instructions

Mounting instructions are enclosed in the package.

Disposal



The device is considered an electronic device for disposal in accordance with the European Guidelines and may not be disposed of as domestic garbage.

- Dispose of the device through channels provided for this purpose.
- Comply with all local and currently applicable laws and regulations.

Technical data

Function	
Communication	Modbus RTU (RS-485)
Supported baud rate	9600; 19200; 38400; 57600; 76800; 115200
Transmission format	1-8-E-1; 1-8-O-1; 1-8-N-1; 1-8-N-2
Bus termination	120 ohm, jumper selection

For detailed information about specific functions, see Basic documentation (A6V11610643*).

Power supply	
Operating voltage	AC 24 V \pm 20 % or DC 13.5...35 V (SELV) or AC/DC 24 V class 2 (US)
Frequency	50/60 Hz at AC 24 V
External supply line protection	Fuse slow max. 10 A or Circuit breaker max. 13 A Characteristic B, C, D according to EN 60898 or Power source with current limitation of max. 10 A
Power consumption	\leq 1.5 VA

Functional data	
Humidity sensor	
Measuring range	0...100 % r.h.
Measuring accuracy at 23 °C and AC/DC 24 V in 0...100 % r.h.	\pm 2 % r.h.
Temperature dependency	\leq 0.05 % r.h./°C
Time constant	< 20 s
Supply air velocity	20 m/s
Temperature sensor	
Measuring range	-40...70 °C
Measuring accuracy at AC/DC 24 V in	
23 °C	\pm 0.3 K
15...35 °C	\pm 0.6 K
-35...+70 °C	\pm 0.8 K
Time constant	< 3.5 min in 2 m/s moved air

Ambient conditions and protection classification	
Protection degree of housing	IP65 according to EN 60529 in built-in state
Protection class	III according to EN 60730-1
Environmental conditions	
Transport	IEC 60721-3-2
• Climatic conditions	Class 2K3
– Temperature	-40...70 °C
– Humidity	< 95 % r.h.
• Mechanical conditions	Class 2M2
Operation	IEC 60721-3-3
• Climatic conditions	Class 3K7
– Temperature (housing with electronics)	-40...70 °C
– Humidity	0...100 % r.h. (with condensation)
• Mechanical conditions	Class 3M2 to IEC 60721-3-3

Standards, directives and approvals	
Product standard	EN 60730-1, EN 60730-2-9, EN 61000-6-2, EN 61000-6-3 Automatic electrical controls for household and similar use
Electromagnetic compatibility (Applications)	For use in residential, commerce, light-industrial and industrial environments
EU conformity (CE)	A5W00037931A *)
RCM conformity	A5W00037932A *)
UL	UL 873, http://ul.com/database
Environmental compatibility	The product environmental declaration (A5W90011832 *) contains data on environmentally compatible product design and assessments (RoHS compliance, materials composition, packaging, environmental benefit, disposal).

General	
Cable lengths for measuring signals Perm. cable lengths	See data sheet of the device handling the signal
Electrical connections screw terminals	1 × 2.5 mm ² or 2 × 1.5 mm ²
Cable entry gland (enclosed)	M 16 × 1.5
Materials and colors	
Base	Polycarbonate, RAL 7001 (silver-grey)
Cover	Polycarbonate, RAL 7035 (light-grey)
Immersion rod	Polycarbonate, RAL 7001 (silver-grey)
Filter cap	Polycarbonate, RAL 7001 (silver-grey)
Mounting flange	PA 66 – GF35 (black)
Cable entry gland	PA, RAL 7035 (light-grey)
Sensor (complete assembly)	Silicone-free
Packaging	Corrugated cardboard
Weight including package	Approx. 234.6 g

*) The documents can be downloaded from <http://siemens.com/bt/download>.

Connection terminals

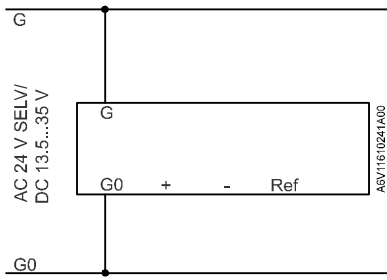

- G Operating voltage AC 24 V \pm 20 % or DC 13.5...35 V
- G0 Ground
- + RS485 Modbus A
- RS485 Modbus B
- Ref GND_ISO

Dimensions

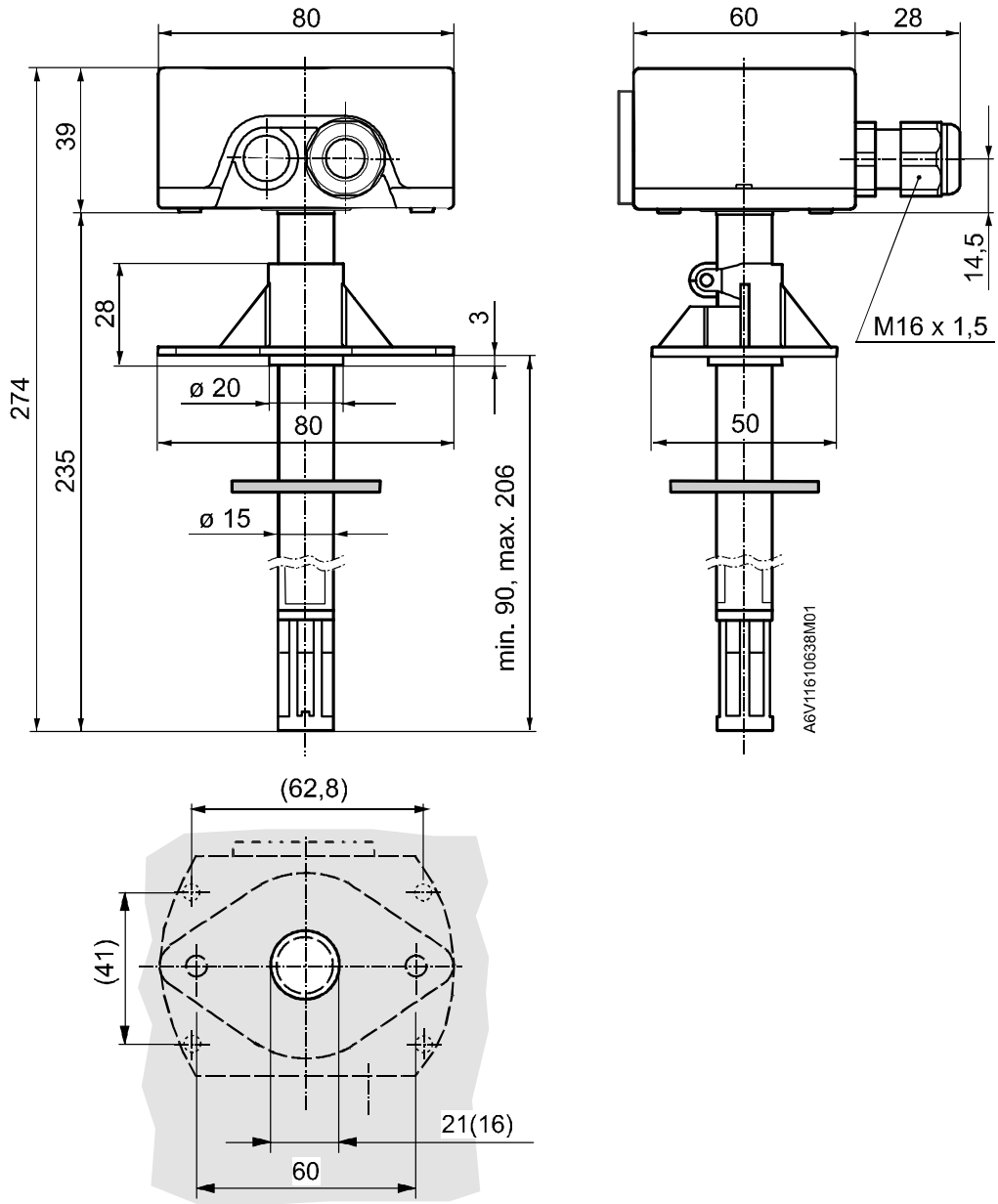

Dimensions in mm

Issued by
Siemens Switzerland Ltd
Smart Infrastructure
Global Headquarters
Theilerstrasse 1a
CH-6300 Zug
Tel. +41 58 724 2424
www.siemens.com/buildingtechnologies

© Siemens Switzerland Ltd, 2019
Technical specifications and availability subject to change without notice.