

Acvatix™

## Rotary Actuator for Ball Valves Modbus RTU

GLB111.9E/MO



### Rotary actuator for ball valves 10 Nm with Modbus communication

- GLB111.9E/MO Operating voltage AC 24 V, 10 Nm
- For air-handling units (AHU) and other heating / cooling applications
- Modbus RTU communication
- UL listed
- For 2-port and 3-port control ball valves, internally threaded connections (VAI61.. and VBI61..) or externally threaded connections (VAG61.. and VBG61..), DN15 to DN50
- For open/close ball valves 2-port and changeover ball valves 3-port, internally threaded connections (VAI60.. and VBI60..) or externally threaded connections (VAG60.. and VBG60..), DN15 to DN50
- For 6-port control ball valve, externally threaded connections (VWG41..), DN20

## Functions

Function	Description
<b>Communication</b>	Modbus RTU (RS-485), galvanically separated
<b>Functions</b>	<ul style="list-style-type: none"> <li>- Setpoint 0..100%,</li> <li>- Actual value for position 0..100%</li> <li>- Override control Open / Close / Min / Max / Stop</li> <li>- Setpoint monitoring and backup mode</li> </ul>
<b>Supported baudrates</b>	9.6, 19.2, 38.4, 57.6, 78.4, 115.2 kbaud
<b>Supported transmission formats</b>	1-8-E-1, 1-8-N-1-, 1-8-O-1, 1-8-N-2
<b>Termination</b>	120 Ω electronically switchable
<b>Supported Modbus function codes</b>	03 Read Holding Registers, 04 Read Input Registers, 06 Write Single Register, 16 Write Multiple registers (max. 120 registers within one message)

For a detailed description of specific functions please refer to the product documentation CE1Z4634.

## Type summary

Product no.	Stock no.	Operating voltage	Positioning signal	Power consumption	Posit. time	Manual adjuster	Position feedback
<b>GLB111.9E/MO</b>	S55499-D206	AC 24 V	Modbus RTU	1 VA / 0,5 W 3 VA / 2,5 W <sup>1)</sup>	150 s	Yes	Yes

Please refer to data sheet **N4698** for information on accessories and spare parts.

<sup>1)</sup> Actuator rotates

## Ordering (Example)

Product no.	Stock no.	Description	Amount
GLB111.9E/MO	S55499-D206	Rotary actuator for Ball Valves with Modbus RTU communication	1

## Equipment combinations

The rotary actuators are suitable for operation of the following Siemens ball valves:

VA..61.. 2-port and VB..61.. 3-port control ball valves								
Control ball valves with:		external threads <sup>2)</sup>	G..B	k <sub>vs</sub> [m <sup>3</sup> /h]	DN	GLB..9E		
internal threads <sup>1)</sup>	Rp					Δp <sub>max</sub>	Δp <sub>s</sub>	
–	–	<b>VAG61.15..</b>	G 1 B	1...6.3	15	350	1400	
<b>VAI61.15..</b>	Rp ½"	–	–	1...10	15			
<b>VAI61.20..</b>	Rp ¾"	<b>VAG61.20..</b>	G 1 ¼ B	4...10	20			
<b>VAI61.25..</b>	Rp 1"	<b>VAG61.25..</b>	G 1 ½ B	6.3...16	25			
<b>VAI61.32..</b>	Rp 1¼"	<b>VAG61.32..</b>	G 2 B	10...25	32			1000
<b>VAI61.40..</b>	Rp 1½"	<b>VAG61.40..</b>	G 2 ¼ B	16...40	40			800
<b>VAI61.50..</b>	Rp 2"	<b>VAG61.50..</b>	G 2 ¾ B	25...63	50			600
Control ball valves with:		external threads <sup>2)</sup>	G..B	k <sub>vs</sub> [m <sup>3</sup> /h]	DN	GLB..9E		
internal threads <sup>1)</sup>	Rp					Δp <sub>max</sub>	Δp <sub>s</sub>	
<b>VBI61.15..</b>	Rp ½"	<b>VBG61.15..</b>	G 1 B	1.6...6.3	15	350		
<b>VBI61.20..</b>	Rp ¾"	<b>VBG61.20..</b>	G 1 ¼ B	4...6.3	20			
<b>VBI61.25-10</b>	Rp 1"	<b>VBG61.25-10</b>	G 1 ½ B	10	25			
<b>VBI61.32-16</b>	Rp 1¼"	<b>VBG61.32-16</b>	G 2 B	16	32			
<b>VBI61.40-25</b>	Rp 1½"	<b>VBG61.40-25</b>	G 2 ¼ B	25	40			
–	–	<b>VBG61.50-40</b>	G 2 ¾ B	40	50			
<b>VBI61.50..</b>	Rp 2"	–	–	40...63	50			

<sup>1)</sup> Data sheet N4211

<sup>2)</sup> Data sheet N4212

VA..60.. / VB..60.. open/close 2-port and changeover ball valves 3-port							
Ball valves with:						GLB..9E	
internal threads <sup>3)</sup>	Rp	external threads <sup>4)</sup>	G..B	$k_{vs}$ [m <sup>3</sup> /h]	DN	$\Delta p_{max}$	$\Delta p_s$
-	-	<b>VAI60.15-9</b>	G 1 B	9	15	350	1400
<b>VAI60.15-15</b>	Rp 1/2"	-	-	15	15		
-	-	<b>VAG60.20-17</b>	G 1 1/4 B	17	20		
<b>VAI60.20-22</b>	Rp 1"	-	-	22	20		
<b>VAI60.25-22</b>	Rp 1"	<b>VAG60.25-22</b>	G 1 1/2 B	22	25		
<b>VAI60.32-35</b>	Rp 1 1/4"	<b>VAG60.32-35</b>	G 2 B	35	32		
<b>VAI60.40-68</b>	Rp 1 1/2"	<b>VAG60.40-68</b>	G 2 1/4 B	68	40		
<b>VAI60.50-96</b>	Rp 2"	<b>VAG60.50-96</b>	G 2 3/4 B	96	50		
<b>VBI60.15-5L</b>	Rp 1/2"	-	-	5	15	350	
<b>VBI60.20-9L</b>	Rp 1"	-	-	9	20		
<b>VBI60.25-9L</b>	Rp 1"	-	-	9	25		
<b>VBI60.32-13L</b>	Rp 1 1/4"	-	-	13	32		
<b>VBI60.40-25L</b>	Rp 1 1/2"	-	-	25	40		
<b>VBI60.50-37L</b>	Rp 2"	-	-	37	50		
-	-	<b>VBG60.15-8T</b>	G 1 B	8	15	350	
<b>VBI60.15-12T</b>	Rp 1/2"	-	-	12	15		
-	-	<b>VBG60.20-13T</b>	G 1 1/4 B	13	20		
<b>VBI60.20-16T</b>	Rp 1"	-	-	16	20		
-	-	<b>VBG60.25-13T</b>	G 1 1/2 B	13	25		
<b>VBI60.25-16T</b>	Rp 1"	-	-	16	25		
<b>VBI60.32-25T</b>	Rp 1 1/4"	<b>VBG60.32-25T</b>	G 2 B	25	32		
<b>VBI60.40-49T</b>	Rp 1 1/2"	<b>VBG60.40-49T</b>	G 2 1/4 B	49	40		
<b>VBI60.50-73T</b>	Rp 2"	<b>VBG60.50-73T</b>	G 2 3/4 B	73	50		

<sup>3)</sup> Data sheet N4213

<sup>4)</sup> Data sheet N4214

VWG41.. 6- port control ball valve							
Ball valves with:						G..B1..9E	
internal threads	Rp	external threads <sup>5)</sup>	G..B	$k_{vs}$ [m <sup>3</sup> /h]	DN	$\Delta p_{max}$	$\Delta p_s$
-	-	<b>VWG41.20..</b>	G1B	0.25 – 4.25	20	200	

<sup>5)</sup> Data sheet A6V10564480

Product no.	Stock no.	Description	Doc. type	Doc. number
AST20	S55499-D165	Handheld tool for commissioning and service	Datasheet	A6V10631836 <sup>1)</sup>
			Operating manual	A6V10555077 <sup>1)</sup>

## Product documentation

Title	Topic	Document ID
Rotary damper actuators without spring return GDB/GLB - Technical basics	Detailed information about rotary actuators without spring return (5/10 Nm), incl. Modbus types	CE1Z4634 <sup>1)</sup>
Mounting Instruction Rotary-type actuator	Mounting / installation instruction for GLB111.9E/MO	A6V10920701 <sup>1)</sup>

<sup>1)</sup> Related documents such as environmental declarations, CE declarations, etc., can be downloaded at the following Internet address:

<http://siemens.com/bt/download>

For more detailed explanations on device states, functions and error display, cf. product documentation CE1Z4634 <sup>1)</sup>.

### Push-button operation

Activity	Push-button operation	Confirmation
Display current address (in reverse order)	Press button < 1s	Current address is displayed
Enter Modbus address with push-button	Press button > 1s and < 5s	See description next page
Enter push-button addressing mode (for use with Climatix™ controllers)	Press button > 5s and < 10s	LED shines orange (release button when red LED gets dark). Timeout after 1 min.
Reset to factory settings	Press button > 10s	LED flashes orange

### LED colors and patterns

Color	Pattern	Description
Green	steady	Start-up
	1s on / 5s off	Fault free operation ("life pulse")
	flashing	Bus traffic
Orange / green	1s orange / 1s green	Device is in override control
Orange	1s on / 1 off	Bus parameters not yet configured
Orange	1s on / 5s off	Backup mode entered
Red	Steady	Mechanical fault / device jammed
	1s on / 5s off	Internal error
	0.1s on / 1s off	Invalid configuration, e.g. Min = Max

### Resetting the device by push button

The rotary actuators can be reset by push-button:

1. Press button for >10s → LED starts flashing **orange**
2. Release button while LED still flashes → LED keeps flashing for 3s
3. If the button is pressed within these 3s, the reset is cancelled.
4. After those 3s → LED shines **red** (reset), then **green** (start-up).

<sup>1)</sup> Related documents such as environmental declarations, CE declarations, etc., can be downloaded at the following Internet address:

<http://siemens.com/bt/download>

### Display current address (digits in reverse order)

The Modbus address can be set without a separate tool by using the push-button and LED.

To display the current address, press button <1s.

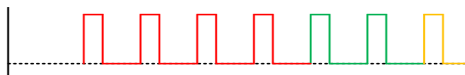
Colors		
1-digits: <b>red</b>	10-digits: <b>green</b>	100-digits: <b>orange</b>
Example for address 124:		
LED		
<b>Note</b>	The address is entered and shown in reverse order.	

### Set new address (digits in reverse order)

- Enter addressing mode:** press button > 1s until LED shines **red**, then release button (before LED gets dark).
- Enter digits:** press button n-times → LED flashes per button press (feedback).  
Colors: 1-digits: **red** / 10-digits: **green** / 100-digits: **orange**
- Store digits:** press button until LED shines in color of following digits – release button,
- Save address:** press button until LED shines **red** (confirmation) → release button.  
An address can be stored at any time, i.e. after setting the 1-digits, or after setting the 1- and the 10-digits.
- Entered address is repeated one times for confirmation.

Note: If button is released before LED shines red, the address is discarded.

### Examples

Set address "124":

- Enter addressing mode
- Set 1-digits: Press button 4-times → LED flashes **red** per button press
- Store 1-digits: press button until LED shines **green** – release button
- Set 10-digits: Press button 2-times → LED flashes **green** per button press
- Store 10-digits: press button until LED shines **orange** – release button
- Set 100-digits: Press button 1-times → LED flashes **orange** per button press
- Store address: press button until LED shines **red** – release button  
→ address is stored and displayed 1x for confirmation

Set address "50":

- Enter addressing mode
- Skip 1-digits: Hold button pressed until LED shines **green** – release button
- Set 10-digits: Press button 5-times → LED flashes **green** per button press
- Store address (skip 100-digits): hold button pressed until LED shines **red** – release button  
→ address is stored and displayed 1x for confirmation

Set address "5":

- Enter addressing mode
- Set 1-digits: Press button 5-times → LED flashes **green** per button press
- Store address: press button until LED shines **red**  
→ address is stored and displayed 1x for confirmation

For a detailed description of specific functions please refer to the product documentation CE1Z4634 <sup>1)</sup>.

Reg.	Name	R/W	Unit	Scaling	Range / enumeration
<b>Process Values</b>					
1	Setpoint	RW	%	0.01	0..100
2	Override control	RW	--	--	0 = Off / 1 = Open / 2 = Close 3 = Stop / 4 = GoToMin / 5 = GoToMax
3	Actual position	R	%	0.01	0..100
256	Command	RW	--		0 = Ready / 1 = Adaption / 2 = Selftest 3 = RelnitDevice / 4 = RemoteFactory Reset

<b>Parameters</b>					
257	Opening direction	RW	--	--	0 = CW / 1 = CCW
258	Adaptive Mode	RW	--	--	0 = Off / 1 = On
259	Operating Mode	RW	--	--	1 = POS
260	MinPosition	RW	%	0.01	0..100
261	MaxPosition	RW	%	0.01	0..100
262	Actuator Running Time	R	s	1	150
513	Backup Mode	RW	--	--	0 = Go to BackupPosition 1 = Keep last position 2 = Disabled
514	Backup Position	RW	%	0.01	0..100
515	Backup Timeout	RW	s	1	0..65535
516	Startup Setpoint	RW	%	0.01	0..100
764	Modbus Address	RW	--	--	1..247 / 255 = "unassigned"
765	Baudrate	RW	--	--	0 = auto / 1 = 9600 / 2 = 19200 3 = 38400 / 4 = 57600 / 5 = 76800 6 = 115200
766	Transmission Format	RW	--	--	0 = 1-8-E-1 / 1 = 1-8-O-1 2 = 1-8-N-1 / 3 = 1-8-N-2
767	Bus Termination	RW	--	--	0 = Off / 1 = On
768	Bus Conf. Command	RW	--	--	0 = Ready / 1 = Load / 2 = Discard
769	Status	R	--	--	See below

<b>Device information</b>					
1281	Factory Index	R	--	--	Cf. product documentation <b>CE1Z4634</b> <sup>1)</sup>
1282-83	Factory Date	R	--	--	
1284-85	Factory SeqNo	R	--	--	
1409-16	TypeASN [Char_16..1]	R	--	--	

<sup>1)</sup> The documents can be downloaded from <http://siemens.com/bt/download>

## Register 769 "Status"

Status			
Bit 00	1 = Local override	Bit 06	1 = Adaption done
Bit 01	1 = Backup mode active	Bit 07	1 = Adaption in progress
Bit 02	1 = reserved	Bit 08	1 = Adaption error
Bit 03	1 = reserved	Bit 09	1 = Selftest failed
Bit 04	1 = Device jammed	Bit 10	1 = Selftest passed
Bit 05	1 = Nom. lifetime exceeded	Bit 11	1 = Invalid configuration

## Supported function codes

Function codes	
03 (0x03)	Read Holding Registers
04 (0x04)	Read Input Registers
06 (0x06)	Write Single Register
16 (0x10)	Write Multiple registers (Limitation: Max. 120 registers within one message)

## Notes

### Safety

#### Caution

#### National safety regulations

Failure to comply with national safety regulations may result in personal injury and property damage.

- Observe national provisions and comply with the appropriate safety regulations.

### Mounting

- Do not open the rotary actuators

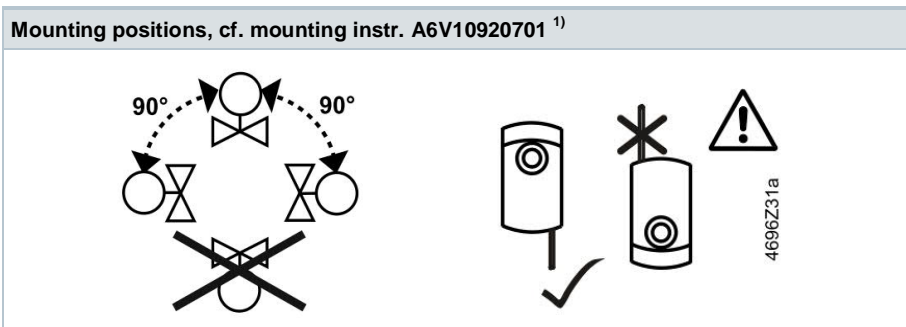

<sup>1)</sup> Related documents such as environmental declarations, CE declarations, etc., can be downloaded at the following internet address:

<http://siemens.com/bt/download>



### Parameterization

The following parameters must be checked or set prior to commissioning:

Parameter	Range	Description	Factory setting
Opening direction	CW (R) / CCW (L)	Opening direction of rotary actuator	CW (R)

### Commissioning workflow 1: Full or partial configuration by tool

When using the AST20 handheld tool, all bus and actuator parameters can be set.

- Connect the AST20 to the rotary actuator and navigate to the bus configuration menu
- Set bus parameters as desired
- Optionally make changes on actuator parameters.

#### Note

With AST20, all parameters can be set using the mass configuration function. The bus parameters are included in the mass configuration function. It can be selected that the address is automatically incremented with each programmed actuator.

### Commissioning workflow 2: Configuration over bus (fully or partially)

The devices can be configured over bus if the pre-commissioning settings allow for a connection between the Modbus master / programming tool and peripheral devices (i.e. non-conflicting addresses and matching baudrate / transmission format).

- Full configuration over bus: If the address is unique per segment when powered up, the device can be accessed by the Modbus master (or programming tool) and the address and other parameters can then be set to the definitive values.
- Partial configuration over bus: If the address is not unique per segment when powered up, each device must get a non-conflicting address before connecting it to the bus (e.g. using the push-button addressing method). After addressing all devices, the remaining configuration can be done over the bus using the default settings for baudrate (auto-baud) and transmission mode for the Modbus master.
- Overwriting the bus configuration over bus uses a timeout. If „1 = Load“ is not written into Reg 768 within 30 seconds, all values are discarded.

Example: Table shows bus configuration registers before and after changing them over bus.

Reg.	Name	Pre-commissioning	New value (ex.)
764	MacAddress	46	12
765	Baudrate	0 = auto	1 = 9600
766	Transmission Mode	0 = 1-8-E-1	3 = 1-8-N-2
767	Termination	0 = Off	0 = Off
768	BusConfigCmd	0 = Ready	1 = Load

## Maintenance

---

The rotary actuators are maintenance-free.

Disconnect the electrical connections from the terminals if you want to work at the device.

## Disposal

---



The device is considered an electronics device for disposal in terms of European Directive 2012/19/EU and may not be disposed of as domestic garbage.

- Dispose of the device through channels provided for this purpose.
- Comply with all local and currently applicable laws and regulations.

## Warranty

Technical data on specific applications are valid only together with Siemens products listed under "Equipment combinations". Siemens rejects any and all warranties in the event that third-party products are used.

## Technical data

Power supply		
Operating voltage	G..B111.9E/..	AC 24 V ± 20 % (SELV) or AC 24 V class 2 (US)
Frequency		50/60 Hz
Power consumption	at 50 Hz	
	Actuator holds	1 VA / 0.5 W
	Actuator rotates	3 VA / 2.5 W
Function data		
Positioning time for nominal rotation angle	G..B111.9E/..	150 s (50 Hz) 120 s (60 Hz)
Nominal / maximum torque	GLB..	10 Nm / < 14 Nm
Nominal / maximum rotation angle		90° / 95° ± 2°
Direction of rotation	Adjustable by tool or over bus	Clockwise (CW) / Counter-clockwise (CCW)
Connection cables		
Cable length		0.9 m
Power supply / Communication	Number of cores and cross-sectional area	5 x 0.75 mm <sup>2</sup>
Service interface	Terminal strip	7-pin, grid 2.00 mm
Communication		
Communication protocol	Modbus RTU	RS-485, galvanically separated
	Number of nodes	Max. 32
	Address range	1...247 / 255 Default: 255
	Transmission formats	1-8-E-1 / 1-8-O-1 / 1-8-N-1 / 1-8-N-2 Default: 1-8-E-1
	Baudrates (kBaud)	Auto / 9.6 / 19.2 / 38.4 / 57.6 / 76.8 / 115.2 Default: Auto
	Termination	120 Ω electronically switchable Default: Off
Degree of protection		
Degree of protection	Degree of protection acc. to EN 60529 (see mounting instruction)	IP54
Safety class	Safety class acc. to EN 60730	III

Environmental conditions		
Applicable standard		IEC 60721-3-x
Operation	Climatic conditions	Class 3K6
	Mounting location	Indoors
	Temperature general	-32...55 °C
	Humidity (non condensing)	5...95 % r. h.
Transport	Climatic conditions	Class 2K3
	Temperature	-25...70 °C
	Humidity	5...95 % r. h.
Storage	Climatic conditions	Class 1K3
	Temperature	-5...45 °C
	Humidity	5...95 % r. h.

Directives and Standards		
Product standard		EN60730-x
Electromagnetic compatibility (Application)		For residential, commercial and industrial environments
EU Conformity (CE)		<b>GLB111.9E/MO</b>
		A5W00000176 <sup>1)</sup>
RCM Conformity		A5W00000177 <sup>1)</sup>
UL, cUL	AC 24 V	UL 873 <a href="http://ul.com/database">http://ul.com/database</a>

Environmental compatibility		
The product environmental declaration A6V10209938 <sup>1)</sup> contains data on environmentally compatible product design and assessments (RoHS compliance, materials composition, packaging, environmental benefit, disposal).		

Dimensions / Weight		
Weight	Without packaging	0.6 kg
Dimensions		71 x 158 x 61 mm

<sup>1)</sup> The documents can be downloaded from <http://siemens.com/bt/download>

## Diagrams

### Internal diagrams

The rotary actuators are supplied with a prewired connecting and communication cable. All interconnected devices must be connected to the same G0.

Core desig.	Core color	Terminal code	Description
1	red (RD)	G	System voltage AC 24 V
2	black (BK)	G0	System neutral AC 24 V
6	violet (VT)	REF	Reference
8	grey (GY)	+	Bus (Modbus RTU)
9	pink (PK)	-	Bus (Modbus RTU)

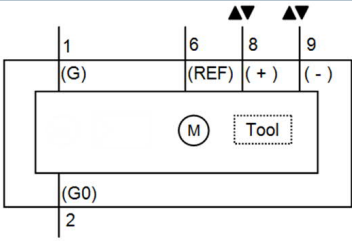

### Note

The operating voltage at terminals G and G0 must comply with the requirements under SELV or PELV. Safety transformers with twofold insulation as per EN 6158 required; they must be designed to be on 100 % of the time.

## Dimensions

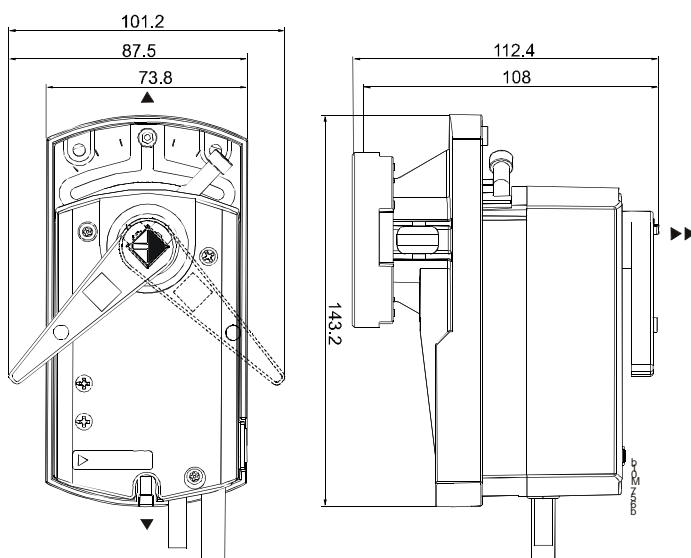

Dimensions in mm

- ▶ = > 100 mm      Minimum clearance from ceiling or wall for mounting,
- ▶▶ = > 200 mm      connection, operation, maintenance etc.

Issued by  
Siemens Switzerland Ltd  
Smart Infrastructure  
Global Headquarters  
Theilerstrasse 1a  
630 Zug  
Switzerland  
Tel. +41 58-724 24 24  
[www.siemens.com/buildingtechnologies](http://www.siemens.com/buildingtechnologies)

© Siemens Switzerland Ltd, 2016  
Technical specifications and availability subject to change without notice.

---

Dokument-ID    A6V10881143\_en--\_c  
Ausgabe        2019-04-25